

27.015.01

Winkel 45°, SDR 11

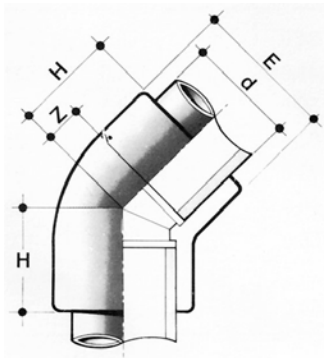

Formgespritzt für Heizelementmuffenschweißung.

HIM

d	Art.-Nr.	E	H	Z	kg	LS	VE
20	727.015.01.020	27,5	21,0	6,5	0,012	1	150
25	727.015.01.025	33,5	24,5	8,5	0,019	1	80
32	727.015.01.032	42,0	29,0	12,0	0,033	1	50
40	727.015.01.040	51,5	35,5	15,0	0,057	1	60
50	727.015.01.050	63,0	42,5	19,0	0,105	1	30
63	727.015.01.063	79,0	51,0	23,5	0,182	1	16
75	727.015.01.075	92,5	51,0	20,0	0,234	1	8
90	727.015.01.090	113,7	82,5	46,0	0,410	1	6
110	727.015.01.110	135,0	98,7	56,0	0,590	1	4

Zulässiger Betriebsüberdruck 10 bar bei Wasser 20° C.